

Operating Instructions

Single Conveyor Unit For Powder SSPET 5

Please note that our address and phone information has changed. Please reference this page for updated contact information.



These manuals are obsolete and are provided only for their technical information, data and capacities. Portions of these manuals detailing procedures or precautions in the operation, inspection, maintenance and repair of the products may be inadequate, inaccurate, and/or incomplete and shouldn't be relied upon. Please contact the ACS Group for more current information about these manuals and their warnings and precautions.

Parts and Service Department

The ACS Customer Service Group will provide your company with genuine OEM quality parts manufactured to engineering design specifications, which will maximize your equipment's performance and efficiency. To assist in expediting your phone or fax order, please have the model and serial number of your unit when you contact us. A customer replacement parts list is included in this manual for your convenience. ACS welcomes inquiries on all your parts needs and is dedicated to providing excellent customer service.

For immediate assistance, please contact:

- North, Central and South America, 8am – 5pm CST +1 (800) 483-3919 for drying, conveying, heating and cooling and automation. For size reduction: +1 (800) 229-2919.
North America, emergencies after 5pm CST (847) 439-5855
North America email: acsuscanadacustserv@corpemail.com
- Mexico, Central & South America
Email: acslatinamericacustserv@corpemail.com
- Europe, Middle East & Africa +48 22 390 9720
Email: acseuropecustserv@corpemail.com
- India +91 21 35329112
Email: acsindiacustserv@corpemail.com
- Asia/Australia +86 512 8717 1919
Email: acsasiacustserv@corpemail.com

Sales and Contracting Department

Our products are sold by a worldwide network of independent sales representatives. Contact our Sales Department for the name of the sales representative nearest you.

Let us install your system. The Contract Department offers any or all of these services: project planning; system packages including drawings; equipment, labor, and construction materials; and union or non-union installations.

For assistance with your sales or system contracting needs please Call:

North, Central and South America +1 (262) 641-8600 or +1 (847) 273-7700 Monday–Friday, 8am–5pm CST

Europe/Middle East/Africa +48 22 390 9720

India +91 21 35329112

Asia/Australia +86 512 8717 1919

Facilities:

ACS offers facilities around the world to service you no matter where you are located. For more information, please visit us at www.acscorporate.com

United States:

ACS Schaumburg – Corporate Offices

1100 E. Woodfield Road
Suite 588
Schaumburg, IL 60173
Phone: + 1 847 273 7700
Fax: + 1 847 273 7804

ACS New Berlin – Manufacturing Facility

2900 S. 160th Street
New Berlin, WI 53151
Phone : +1 262 641 8600
Fax: + 1 262 641 8653

Asia/Australia:

ACS Suzhou

109 Xingpu Road SIP
Suzhou, China 215126
Phone: + 86 8717 1919
Fax: +86 512 8717 1916

Europe/Middle East/Africa:

ACS Warsaw

Ul. Działkowa 115
02-234 Warszawa
Phone: + 48 22 390 9720
Fax: +48 22 390 9724

India

ACS India

Gat No. 191/1, Sandbhor Complex
Mhalunge, Chakan, Tal Khed,
Dist. Pune 410501, India
Phone: +91 21 35329112
Fax: + 91 20 40147576

Sterling Material Processing

5200 West Clinton Ave.

Milwaukee, WI 53223

Telephone: (414) 354-0970

Fax: (414) 354-6421

www.sterlco.com

Technical service:

Service department

Telephone: **(800) 423-3183**

Edition: 02/01

Sterling order confirmation no.: _____

These operating instructions are for:*

(* Please fill in personally)

Serial number: _____

Built in: _____

Date of delivery: _____

Number of delivery: _____

Date of commissioning: _____

Location: _____

Group of machines: _____

Sterling Material Processing retains all rights to change the information in these operating instructions at any time without notice.

We assume no liability for any errors or direct or indirect damage resulting in context with these operating instructions.

Copying, translation or publication in any form except for personal use of purchaser requires approval from Sterling Material Processing.

All rights reserved.

Table of contents

1. Safety instructions	6
1.1. Warnings and symbols	7
1.2. Explanations and information	8
1.3. For your safety	9
1.4. For the operating safety of the equipment	12
2. Assembly instructions	13
2.1. Assembly	14
2.2. Mounting the suction pipe MV	16
2.3. Electrical connection	17
2.3.1. Installation of the “flap switch” signal line	18
2.3.2. Installation of the signal line of the ZKW (optional)	18
2.3.3. Installation of an alarm indicating device at the SSE controller (optional)	19
2.4. Compressed-air supply	20
3. Functional description	21
3.1. General	22
3.2. Controller SSE	23
3.3. Controller SSP	25
4. Putting into operation	26
4.1. Checking the pipe system	27
4.2. Adjusting the suction pipes	28
4.3. Setting the controller SSE	29
4.4. Setting the controller SSP	31
4.5. Initial conveying operations	32
4.6. Alarm Messages displayed on the controller SSE	32
4.7. Alarm Messages displayed on the controller SSP	34
4.8. Switching off the unit	34

5. Maintenance 35

 5.1. Maintenance intervals 37

 5.2. Servicing the conveyor 38

 5.2.1. Cleaning/replacing the filter cartridges of the cleaning unit. 38

 5.2.2. Changing the sealing ring of the outlet flap 40

 5.2.3. Adjusting the flap switch 41

 5.3. Replacing carbon brushes at turbine 42

6. Technical data 44

7. Parts list 46

8. Accessories 49

1. Safety instructions



These safety instructions apply to all persons within the range of action of the equipment.

Please inform all persons within the range of action of the equipment of the direct and indirect hazards connected with the equipment.

These operating instructions are to be used by all persons assigned activities connected with the equipment.

Knowledge of the English language is prerequisite.

Ensure in each case that the operating personnel are familiar with the operating instructions and the function of the equipment.

1.1. Warnings and symbols

The following warnings and symbols are used in these operating instructions:



This symbol indicates danger to life! Fatal or serious injury is possible if the corresponding instructions, regulations or warnings are not observed.



This symbol indicates that serious injury is possible if the corresponding instructions, regulations or warnings are not observed.



This symbol indicates that extensive damage to equipment is possible if the corresponding instructions, regulations or warnings are not observed.



This symbol indicates information important for becoming familiar with the equipment, i.e. technical correlations.



This symbol indicates that a technical term is explained at this point.

1.2. Explanations and information

Various terms and designations are used in these operating instructions to ensure clarity. Therefore please note that the terms used in the text stand for the corresponding explanations listed below.

- **Equipment**
“Equipment” can mean an individual unit, a machine or an installation.

- **Operating personnel**
The “operating personnel” are persons operating the equipment on their own responsibility or according to instructions.

- **Operator**
The “operator” of the equipment (production manager, foreman, etc.) is the person responsible for all production sequences. The operator instructs the operating personnel of what is to be done.

- **Operating instructions**
The “operating instructions” describe the interaction of the equipment, production sequences or methods. The operating instructions must be compiled by the operator of the equipment.

- **Equipment foreman**
When several operating personnel work on one machine, the “equipment foreman” coordinates the sequences. The equipment foreman must be appointed by the operator.

- **Trained personnel**
“Trained personnel” are persons who, due to their training, are authorized to carry out the required work.

1.3. For your safety

- The operating personnel of this equipment must be at least 16 years old.
- Please read these operating instructions carefully before taking into operation for the first time. Contact us should questions arise.
This avoids injury and damage to equipment!
- These operating instructions must be kept available at all times at the place of operation of the equipment. Improper operation results in danger of accidents!
- Please note that, for reasons of clarity, not all conceivable cases regarding operation or maintenance of the equipment can be covered in these operating instructions.
- Please observe all safety instructions and warnings on the equipment.
This avoids injury and damage to equipment!
- All work on the equipment is to be carried out by persons whose qualifications are specified in the pertaining chapters of the operating instructions.
Improper operation results in danger of accidents!
- The proper working clothes are to be worn during any work on the equipment.
This avoids injury!
- Compare the connected loads with those of the mains supply.
Danger of injury through electrical shock!
- When using lifting gear, please observe the pertaining regulations.
Caution: Danger of accidents!
- The local regulations and requirements pertaining to this equipment must be observed.
- Disconnect electrical components from the mains supply before work is carried out on these components. Caution: Danger to life through electrical shock!

- Do not modify, add other equipment or change the design of the equipment without the approval of the manufacturer. Caution: Danger of accidents!
- Compile detailed operating instructions based on these operating instructions for the sequence of procedures to be carried out on this equipment.
Improper operation results in danger of accidents!
- Appoint an equipment foreman to be responsible for the equipment.
- Ensure that the operating personnel are provided detailed instruction in the operation of the equipment. Improper operation results in danger of accidents!
- When the main switch is switched off for reasons pertaining to safety, it must be secured against unauthorized activation. Caution: Danger of accidents!
- Before starting maintenance work, appoint a supervisor.
- Inform the responsible personnel before maintenance work on the system is started. Caution: Danger of accidents!
- Disconnect the equipment from mains supply before starting maintenance procedures to ensure that it cannot be switched on unintentionally.
Caution: Danger of accidents!
- Repair work may be carried out by trained personnel only.
Caution: Danger of accidents!
- Never operate the equipment when partially dismantled.
Caution! Danger exists that limbs may be caught; danger of electrical shock!
- In case of malfunction, shut down the equipment immediately. Have malfunctions corrected immediately. Caution: Danger of accidents!
- The equipment is intended only for conveying granulated plastics and additives.
Other use of the equipment is contrary to its specifications.

- This equipment is not suitable for foods processing.
- Observe that sound intensity levels over 85 dB(A), may cause prolonged damage to health. Use suitable earmuffs. This avoids impairment of hearing!
- Attachments not supplied by Sterling must be manufactured in accordance with safety regulation EN 294. Caution! Danger of accidents!
- Check all lines, hoses and screwed connections regularly for leaks and obvious damage. Repair damage immediately. Caution: Danger of accidents!
- Depressurize all system sections of the equipment before carrying out any repair work. Caution: Danger of accidents!
- The equipment may only be operated when all the associated components are properly connected up and in accordance with the relevant regulations.
- The safety instructions of the connected machines must be followed.

1.4. For the operating safety of the equipment

- Never change settings if the consequences are not precisely known.
- Use only original Sterling spare parts.
- Please observe the maintenance intervals.
- Keep record of all maintenance and repair procedures.
- Please note that electronic sub-assemblies can be damaged by static discharges.
- Check all electrical connections for proper fit before the equipment is taken into operation for the first time and at regular intervals.
- Never adjust sensors without exact knowledge of their function.
- Please note that the ambient temperature of the control unit must not exceed 45°C (113°F).
- Adjust the suction pipes properly.
- Please observe that a level indicator is required when conveying from granulators.
- Mount the single conveyor unit in such a way that the outlet flap swings in a right-hand angle to the direction of machine movement.
- Please ensure that all plugs are correctly plugged in.
- Observe the bearing capacity of the machine flange.
- The operating instructions of the machines to which it is connected should be obeyed.

2. Assembly instructions



These installation instructions are intended for persons with skills in electrical and mechanical areas due to their training, experience and received instructions.

Personnel using these installation instructions must be instructed in the regulations for the prevention of accidents, the operating conditions and safety regulations and their implementation.

Ensure in each case that the personnel are informed.

The installation instructions provided in the corresponding operating instructions apply for all connected equipment.

Please observe all safety regulations for the operation of lifting gear.

All installation work must be carried out with the equipment disconnected from electrical power and compressed air supply.



For installation work taking place at heights of over approx. 6 feet (1829) in, use only ladders or similar equipment and working platforms intended for this purpose. At greater heights, the proper equipment for protection against falling must be worn.

Use only suitable lifting gear which is in proper working order and load suspension devices with sufficient carrying capacity. Do not stand or work under suspended loads!

Use only suitable workshop equipment.



Install the equipment such that all parts are easily accessible; this facilitates maintenance and repair work.

2.1. Assembly

The single conveyor unit is insensitive to shocks and can be mounted directly onto the processing machine, on a machine hopper, a drying hopper or a dosing and blending unit.

The equipment is delivered as a complete assembly.

Unpack the equipment.

Remove the plastic stopper from the material inlet nozzle.

Remove the adhesive tape from the exit flap.



The controller must be freely accessible.

Mounting on fixed machine throats or intermediate containers is done by means of strap retainers.

Please check during assembly that the admissible bearing loads are not exceeded.

Mount the conveyor in such a way that the outlet flap swings in a right angle to the direction of machine movement.

Please check that all connecting points are tight to ensure that the conveying performance is not impaired.

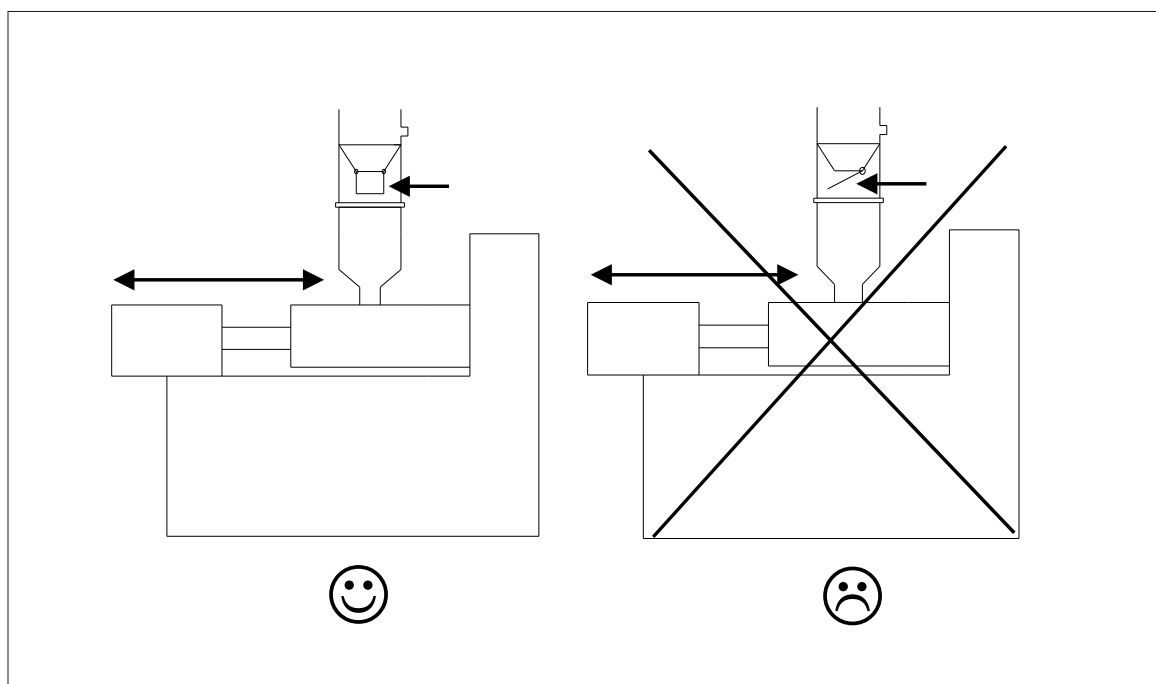

Assembly

2.2. Mounting the suction pipe MV

The suction pipe consists of an inner pipe (A) and an outer pipe (B) which can be offset against each other.

Connect the inner pipe with the straight end to a flexible hose:

Push the free pipe end into the flexible line to a depth of approx. 4-5 cm (1.67-1.97in.)

Connect both parts by means of a hose clamp.

Please observe that the length of the hose should not exceed 3 m (9.84 in.)

Please check that the outer pipe is not covered as it provides for unhindered access of ambient air.



When conveying from silos, material hoppers and storage containers, a suction box with 1-3 suction pipes is required.

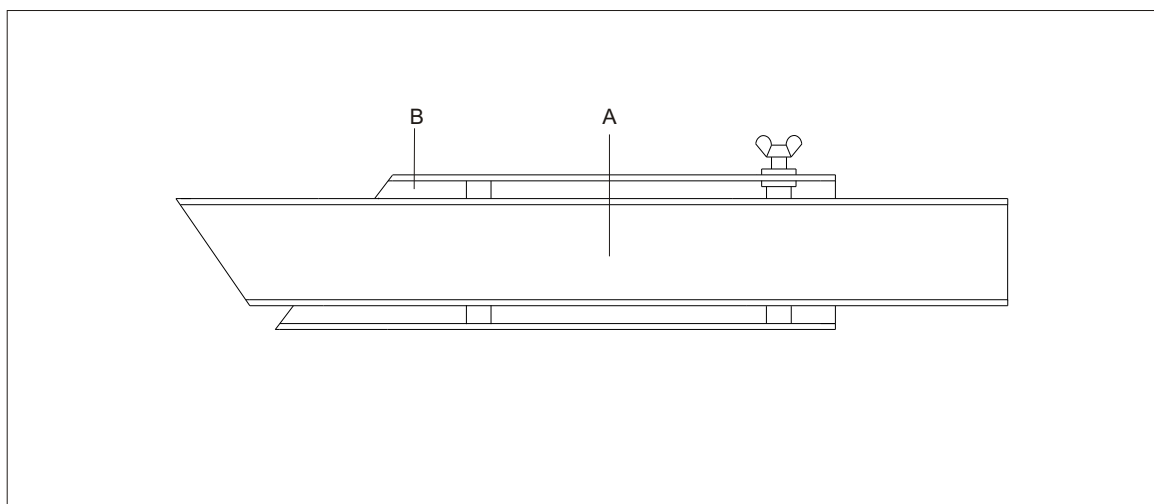

MV

2.3. Electrical connection



Electrical connection of the equipment must be carried out by qualified personnel only.

Ensure that the regulations of the local electric supply company are observed.

The operating voltage is 230 V/50 Hz.
Special voltages on request.

The connected load is approx. 1200 W.

The equipment is connected to mains supply by a device plug.

Separate fuse protection of the wall socket is required (max. 16 A).

2.3.1. Installation of the “flap switch” signal line

Insert the appliance plug of the “flap switch” signal line into the “flap switch” connector (A) on the lower side of the controller.

2.3.2. Installation of the signal line of the SKW (optional)

Insert the appliance plug of the “SKW (= Two Component Proportioning Valve)” signal line into the “SKW” connector (B) on the lower side of the controller.

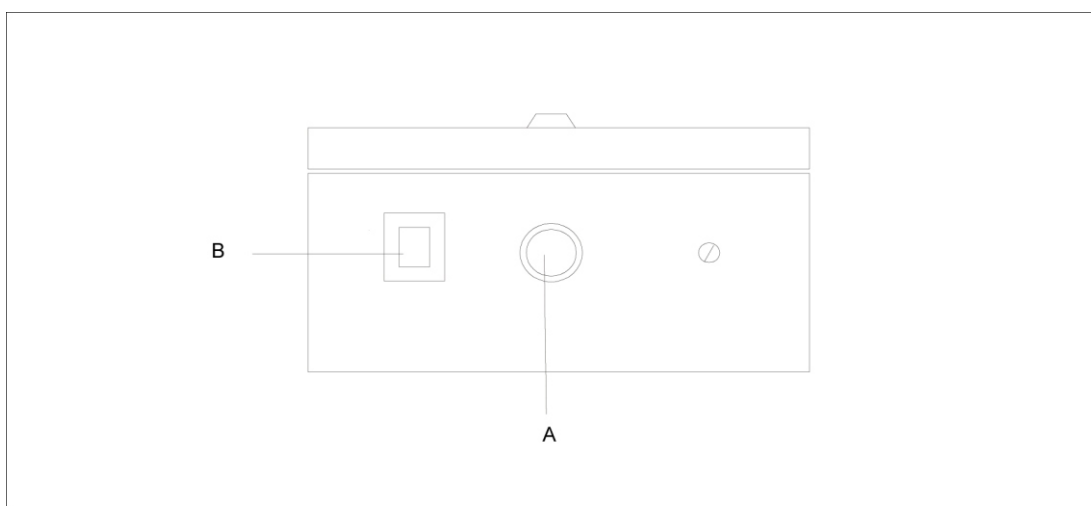

2.3.3. Installation of an alarm indicating device at the SSE controller (optional)



This work must be carried out by qualified personnel only.

Disconnect the unit from mains supply by the device plug before you begin with works on the controller. Danger to life!

The connection is potential-free and rated for no more than 5 A.



An additional alarm indicating device (e.g. horn, signal light) can be connected.

You need an “acknowledgement key” for 24 V (e.g. by Rafi Company).

2.4. Compressed-air supply

For operating the cleaning unit, a compressed-air supply is necessary.



Depressurize compressed-air supply lines which must be opened.



Compressed air must be dewatered, dustfree and oilfree.

Install a maintenance unit if required.

Adjust pressure to a max. value of 6 bar (87.02 PSI) (system overpressure).

Check compressed-air piping for correct installation and assembly.

Check fittings, length and quality of the hose connections for agreement with requirements.

The operating pressure is 5-6 bar (72.52-87.02 PSI) (system overpressure).

Check the compressed-air supplied by the plant's supply network.

Adjust compressed-air pressure to 5-6 bar (72.52-87.02 PSI) (system overpressure).

Connect the unit to the plant's supply network by means of a hose.

3. Functional description



This functional description is intended for all operating personnel of the equipment.

Prerequisite for this functional description is general knowledge of conveying systems.

Ensure in each case that the operating personnel are sufficiently informed.

3.1. General

The single conveyor unit functions according to the principle of suction conveyance. A high-performance turbine, mounted permanently on the device, provides for the vacuum that is required to convey the material into the separator.

In the separator the material is separated from air. After the conveying time is finished the turbine is switched off and the material emptied into the material intermediate hopper. If the filling level remains below the outlet flap of the single conveyor unit, a starting pulse is triggered and sent to the controller. Then the conveyance is restarted. This process repeats so often until the material intermediate hopper is filled. Afterwards the conveyance is stopped until a new starting pulse is triggered and sent to the controller.

The automatic filter cleaning takes place by adjustable compressed-air shocks (pulse duration).

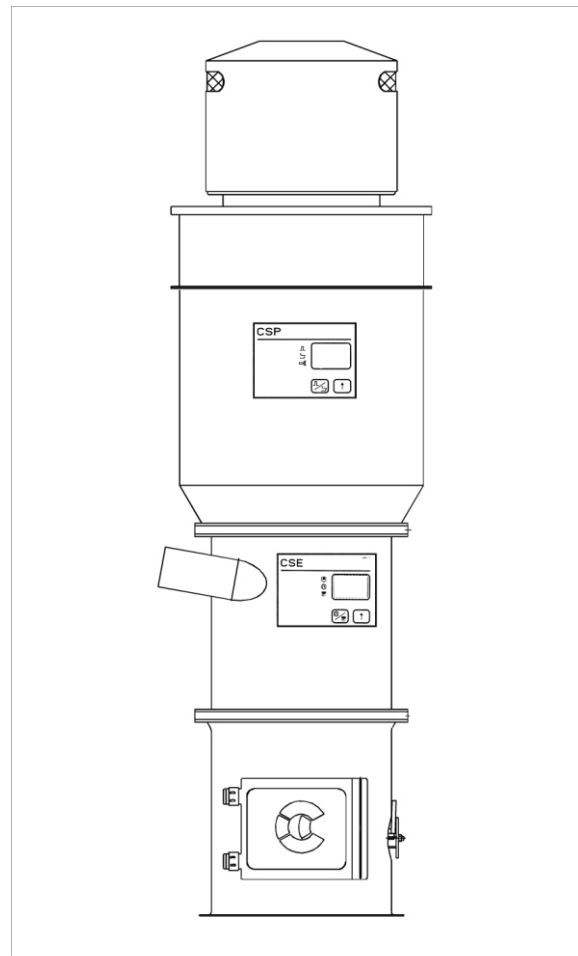

CSPE 5



The filter-cleaning process takes place during the conveying process.

The filter cartridges are cleaned in adjustable intervals (time interval).

3.2. Controller SSE

The setting for the conveying time and the line clear time are made via the keys (A1: “change-over” key, A2: “arrow key”) on the front of the control system. The values which have been set will be displayed on the display (B). The values which have been set are maintained after the machine has been shut off.

3 LEDs indicate the respective modes of operation: cleaning (C), conveying (D), line clearing (E).



The conveying time can be set from 1 to 99 seconds.
 The line clear time can be set from 0 to 99 seconds.
 The clearing time consists of 2 seconds.
 The emptying time consists of 8 seconds.
 When the unit is switched on all LEDs blink and the software version is displayed.

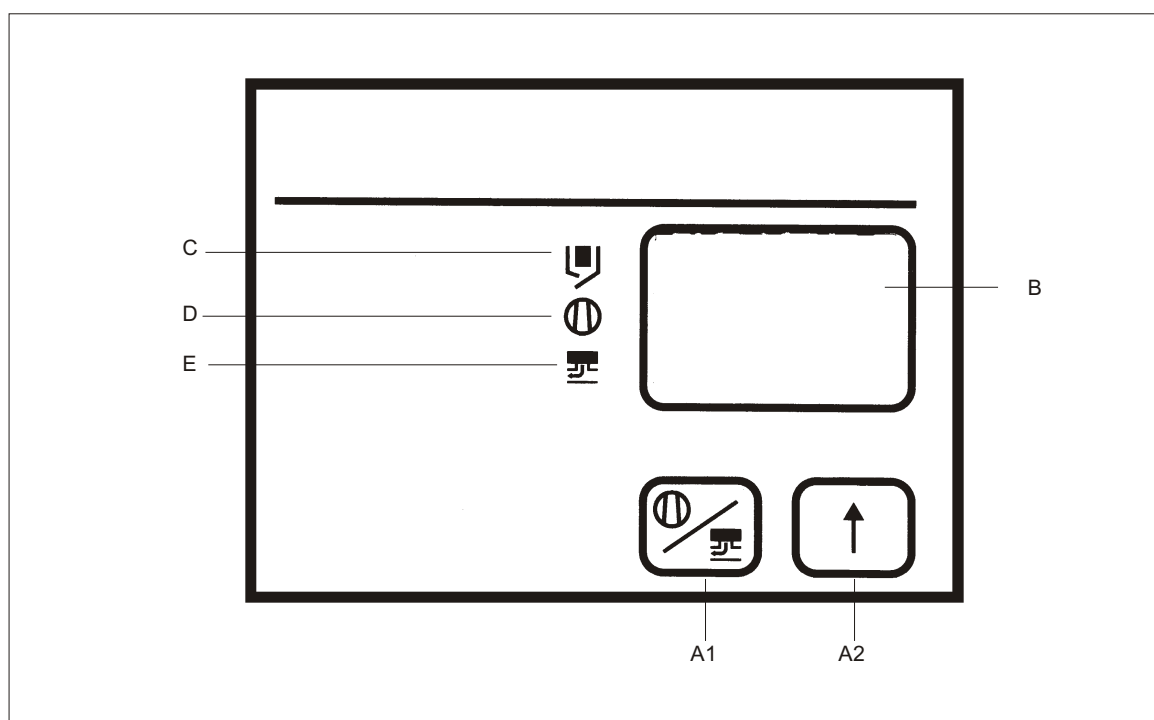

Controller SSE

If a material clearing valve has been installed (option) residues of flowing material will be cleaned from the conveying line during the line clear time.

If a disturbance occurs in the unit, an alarm message will be issued (option, only if the alarm indicating device has been activated).



An "E" appears in the display and an error number.

The alarm indicating device (signal siren, horn) reacts.

3.3. Controller SSP

The setting for the conveying time and the line clear time are made via the keys (A1: “change-over” key, A2: “arrow key”) on the front of the control system. The values which have been set will be displayed on the display (B). The values which have been set are maintained after the machine has been shut off.

3 LEDs indicate the respective modes of operation: pulse duration (C), time interval (D), without function (E).



The pulse duration can be set to 0.5, 1.0 or 1.5 seconds.

The time interval can be set from 5 to 20 seconds.

When the unit is switched on all LEDs blink and the software version is displayed.

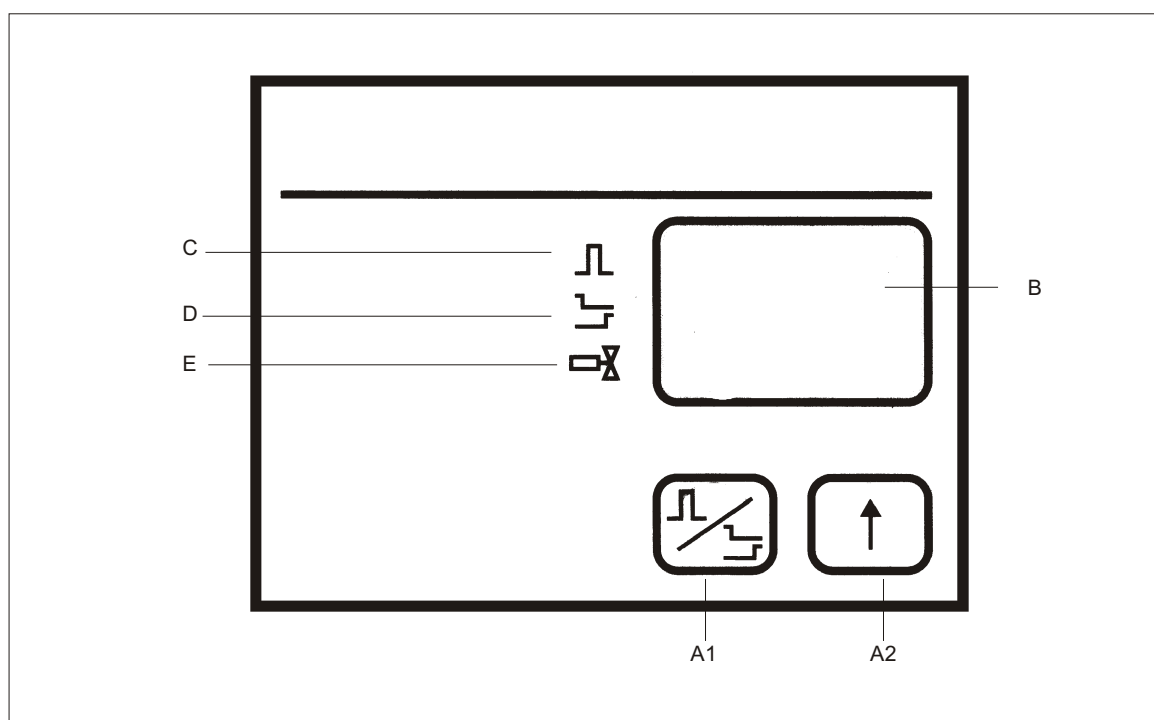

Controller SSP

4. Putting into operation



This chapter is intended for operating personnel.

Prerequisite for this chapter is general knowledge of the operation of conveying systems.

Also prerequisite for this chapter is that the functional description has been read and understood.

Ensure in each case that the operating personnel are sufficiently informed.



Make sure the plastic stopper has been removed from the material inlet nozzle.

Make sure the adhesive tape has been removed from the exit flap.

4.1. Checking the pipe system

Remove the flexible hose from the connected material takeup.

Close the open end of the hose with your hand.

Connect the unit to mains supply by the device plug.

If the turbine is operating, your hand must feel the suction within few seconds.

If you don't feel the vacuum it means that the pipe system is not tight.

Check the pipe system and seal any untight points you may have identified.

Reconnect the conveying hose.

Disconnect the unit from mains supply by the device plug.

4.2. Adjusting the suction pipes

The suction pipes have to be adjusted exactly to ensure troublefree operation.

1. Set the suction pipes to their home position.



At home position the inner pipe of the suction pipe protrudes about 120-160 mm (4.72-6.30 in) from the outer pipe at the top end.

2. Start a conveying operation.

Connect the unit to mains supply by the device plug.

3. Observe the flexible hose at the suction pipe.

The flexible hose must not show any pulsating movement.

4. Observe the flexible hose at the separator.

The conveying hose must only move during in-feed.

If the conditions (points 3 + 4) are not met:

Pull the inner pipe further out of the outer pipe until there is no more jerky conveyance.

If the conditions (points 3 + 4) are met:

Push the inner pipe slowly into the outer pipe until pulsating of the flexible hose or shock conveyance occurs.

Now pull the inner pipe slightly back again until the hose stop pulsating.

Select a setting between the two pipes to ensure that enough air can flow into the material pipe.

Once you have reached a satisfactory conveying result turn the wing screw at the suction pipe tight.

4.3. Setting the controller SSE



The filling capacity of the hopper loader may not exceed the material inlet.



The setting is independent of the conveying line and the material to be conveyed.

It is only possible to set the conveying time / line clear time when the unit is not conveying any material.

Setting the conveying time

Press the “**arrow key**”.

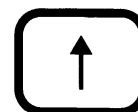

The conveying time which was last selected appears in the display.

1-99 seconds may be set for the conveying time.

The turbine is running but no material is being conveyed:

Reduce the conveying time.

The conveying capacity is too low:

Increase the conveying time.

Setting the line clear time

Press the “**arrow key**” and the “**change-over**” key.

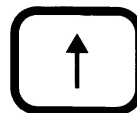

The line clear time which was last selected appears in the display.

0-99 seconds may be set for the line clear time.



If no line clear valve has been installed enter “0”.

4.4. Setting the controller SSP



It is only possible to set the pulse duration / time interval when the unit is not conveying any material.

Setting the pulse duration

Press the “**arrow key**”.

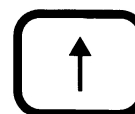

The pulse duration (= duration of a cleaning pulse) which was last selected appears in the display.

0.5, 1.0 or 1.5 seconds may be set for the pulse duration.

Setting the time interval

Press the “**arrow key**” and the “**change-over**” key.

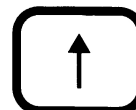

The time interval which was last selected appears in the display.

5-20 seconds may be set for the time interval between 2 cleaning pulses.

4.5. Initial conveying operations

Metal shavings may be inside the pipe from cutting down pipes into lengths. These are pulled during the first conveying process and collected in the separator.



This material should not be used again.

4.6. Alarm Messages displayed on the controller SSE

If a disturbance occurs in the unit, an alarm message will be issued (option, only if the alarm indicating device has been activated).



An “E” appears in the display and an error number.

The alarm indicating device (signal siren, horn) reacts.



The control system can only restart operation when the malfunction has been corrected.

Press the “acknowledgement key”.



The cause of the malfunction will not be corrected by pressing the “acknowledgement key”.

The following error messages can be displayed:

“E1”

The alarm message “E1” is displayed when no material has been conveyed during 3 consecutive conveying cycles.

Check that sufficient material is being conveyed.

Check that the flap switch is set correctly.



When the malfunction has been corrected press the key.

“E2”

If the control system becomes too hot during operation ($>70^{\circ}\text{C}$) (158°F) the “E2” alarm message is displayed and the unit is switched off.

Ensure that the control system is sufficient cooled.



The unit starts automatically after the cooling down phase.

4.7. Alarm Messages displayed on the controller SSP

If a disturbance occurs in the unit, an alarm message will be issued.



An "E" appears in the display and an error number.

"E2"

If the control system becomes too hot during operation ($>70^{\circ}\text{C}$) (158°F) the "E2" alarm message is displayed and the unit is switched off.

Ensure that the control system is sufficient cooled.



The unit starts automatically after the cooling down phase.

4.8. Switching off the unit

Disconnect the unit from mains supply by the device plug.

5. Maintenance



This chapter is intended for persons with skills in electrical and mechanical areas due to their training, experience and received instructions.

Personnel using the instructions in this chapter must be instructed of the regulations for the prevention of accidents, the operating conditions and safety regulations and their implementation.

Ensure in each case that the personnel are informed.

For maintenance work taking place at heights of over approx. 1829 mm (6 ft), use only ladders or similar equipment and working platforms intended for this purpose. At greater heights, the proper equipment for protection against falling must be worn.

Use only suitable lifting gear which is in proper working order and load suspension devices with sufficient carrying capacity. Do not stand or work under suspended loads!

Ensure that the electric motors/switch cabinets are sufficiently protected against moisture.

Use only suitable workshop equipment.

Before starting maintenance work, appoint a supervisor.

Inform the responsible personnel before maintenance work on the system is started.

Never operate the equipment when partially dismantled.

All maintenance and repair work **not** described in this chapter may only be carried out by Sterling service personnel or authorized personnel (appointed by Sterling).



Disconnect the equipment from mains supply before starting maintenance procedures to ensure that it cannot be switched on unintentionally.

Depressurize all system sections of the equipment before carrying out any repair work.



Please observe the maintenance intervals.

Before starting maintenance work, clean the equipment of oil, fuel or lubricants.

Ensure that materials and incidentals required for operation as well as spare parts are disposed of properly and in an environmentally sound manner.

Use only original Sterling spare parts.

Keep record of all maintenance and repair procedures.

5.1. Maintenance intervals

Daily:	Check warning signs on equipment for good legibility and completeness
Weekly:	Check the maintenance unit Check operating pressure of the plant's supply network (5-6 bar (72.52-87.02 PSI) system overpressure)
Monthly:	Check function of the device plug Check the sealings on the filter cartridges (according to the accumulation of dust)
Every 6 months:	Check all electrical and mechanical connections for tight fit Check the settings on the level probes (if present) Check filter contamination, if necessary clean or replace the filter cartridges
Annually:	Replace outlet valve sealing Adjust valve switch
After 1000 operating hours:	Replace carbon brushes



The given maintenance intervals are average values.

Check whether in your individual case the maintenance intervals must be shortened.

5.2. Servicing the conveyor



Disconnect the unit from mains supply by the device plug.

Depressurize all system sections of the equipment (only units with active cleaning).

Disassembly the unit.

5.2.1. Cleaning/replacing the filter cartridges of the cleaning unit



Clean the separator hopper each time you are changing the materials.

Use only cleaning agents which fulfil the corresponding requirements.

Only clean the separator hopper with compressed-air and/or a brush.



The conveying capacity is diminished by a clogged filter cartridge.

Removal

Open the tension ring (A) and remove the hopper loader lid (B).

Open the tension ring (C) and remove cleaning unit (D).

Release clamping devices of the filter cartridges.

Remove the filter cartridges (E) from the intermediate platform.

Clean the filter cartridges (E) from the inside out by means of compressed air.

or

Replace the filter cartridges by new ones.

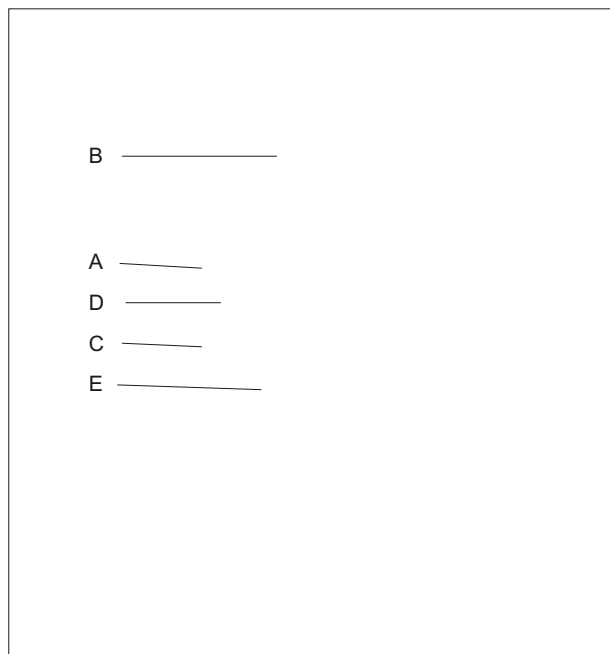

SSPET5

Installation

Insert filter cartridges (E) into the opening of the intermediate platform.



Make sure that the sealing pad is tightly fitted between filter cartridges and intermediate platform.

Mount clamping devices of the filter cartridges.

Mount the cleaning unit (D) and the tension ring (C).

Mount the hopper loader lid (B) and the tension ring (A).



Order number filter cartridges (= 4 pcs.): ID 83379

Install the unit.

5.2.2. Changing the sealing ring of the outlet flap

Draw the old sealing ring off the nozzle of the material outlet.

Install the new sealing ring.

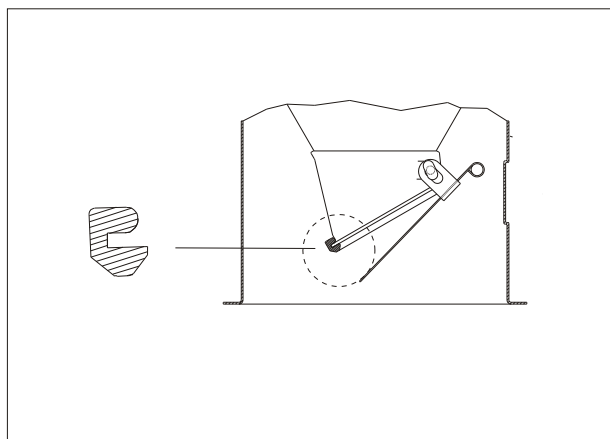

Assembly sealing ring



Observe the direction of installation.

Install the unit.



Order number

sealing ring: ID 23098

5.2.3. Adjusting the flap switch

Remove the connecting plug “flap switch” from the connection housing of the hopper.

Connect an ohmmeter to PINS 2 and 3 of the connecting plug “flap switch”.

Release the nuts (A) of the flap switch (B) until the support can be displaced.

Open the outlet flap (C) so far that the front tip of the outlet flap is approx. 30 mm (1.18 in.) away from the sealing surface.

Displace the flap switch (B) until the contact of the magnet switch is closed.

Tighten the nuts (A) of the flap switch.

Check the adjustment:

In case of free hanging outlet flap (empty hopper loader) the contact of the magnet switch must be closed.

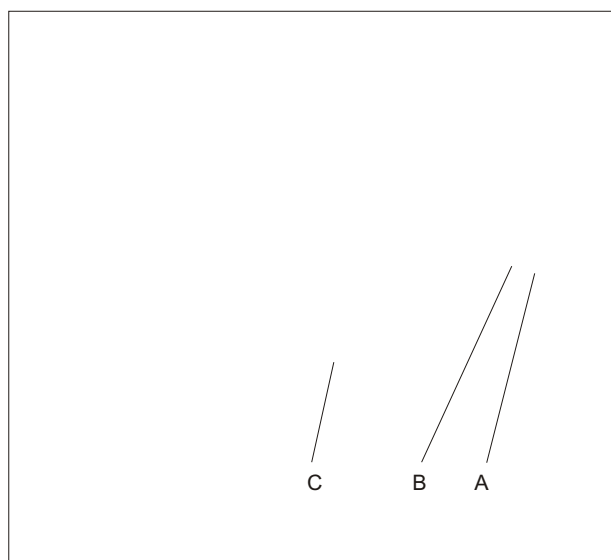

Outlet flap

If the outlet flap cannot be properly adjusted, replace the flap switch or the outlet flap with magnet.

Install the hopper.



Order numbers

switch with plug: ID 28839

outlet flap with magnet: ID 23093

5.3. Replacing carbon brushes at turbine



This work must be carried out by qualified personnel only.

Disconnect the unit from mains supply by the device plug before you begin with works on the controller. **Danger to life!**

Depressurize all system sections of the equipment.

Disassembly the unit.

Remove the screws (A) at the lid.

Remove the lid (B).

Loosen the ground connections (C) and the mains cable (D).

Remove the screws (E) at the turbine housing.

Remove the turbine housing (F).

Remove the cover (G).

Loosen the brush holder lock.

Pull out the brush holder.

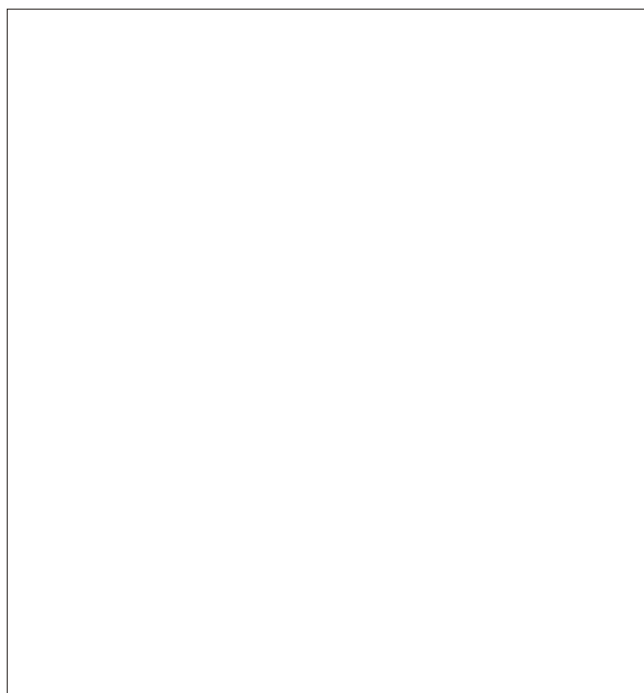

SSPET5

Installation

Mount the brush holder.

Mount the cover (G).

Mount the turbine housing (F).

Mount the screws (E) at the turbine housing.

Mount the ground connections (C) and the mains cable (D).

Mount the lid (B).

Mount the screws (A) at the lid.

Install the unit.



Observe that no cables will be squeezed.

Carbon brushes can be replaced twice.
After that the turbine has to be completely replaced.



Order numbers

Turbine (1200 W): ID 83380

Carbon brushes (switching off): ID 85628

6. Technical data

Basic Version

- Integrated control SSE / SSP
- Integrated vacuum pump
- Two component valve output
- Parts coming in contact with material are made of stainless steel
- Simple mounting to dosing and blending units due to compact and weight saving design

Optional Features

- Integrated filter with automatic filter cleaning
- Alarm output
- Granulator output
- Automatic shut-down with lack of material

Performance

- Typical conveying capacity
SSPET5: up to 300 kg/hr (660 lbs/hr)
- Hopper loader capacity
SSPET5: approx. 5 l (0.28 cf.)
- Connected load 230 V, AC, 50/60 Hz, 1.2 kW

Dimension Sheet

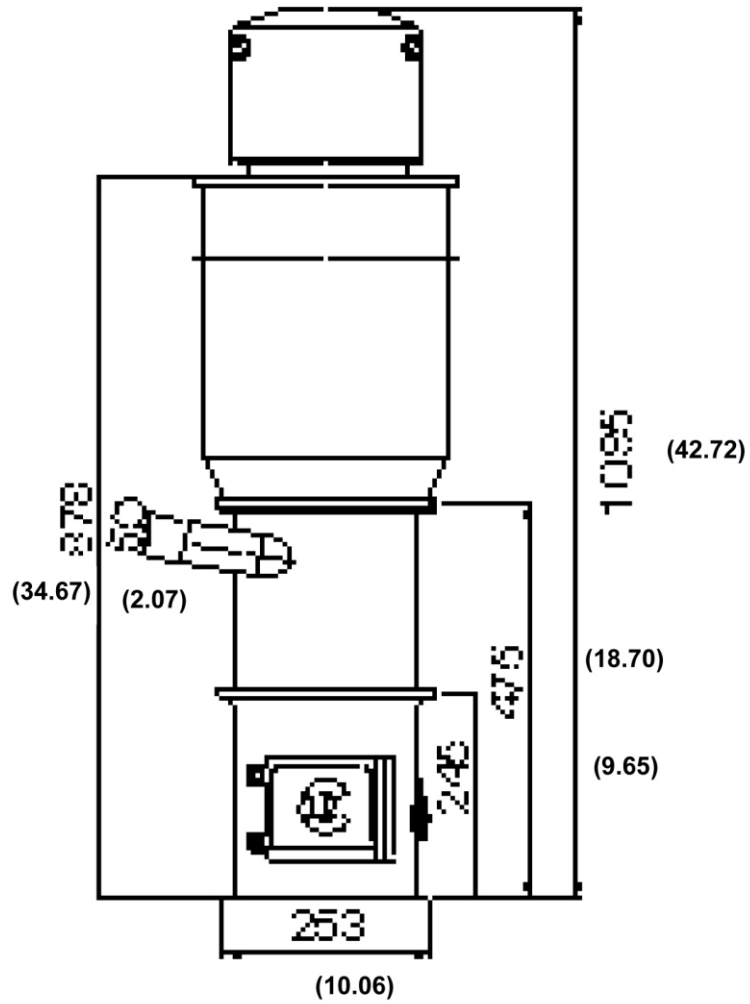

Dimensions and data without obligation. Dimensions in mm. (in.) Specifications may be subject to alterations.

7. Parts list



This parts list is only for the use of trained personnel only.

All other persons are not permitted to repair or to change the equipment.

SSPET5

SSPET5

Pos.	Order no.	Designation
1	85628	Brush holder with carbon (brush switching off)
2	83380	Turbine (1200 W)
3	97556	Solenoid valve
	85460	Ventilation valve
	85462	Compressed-air container
4	83080	Controller SSP
5	83379	Filter cartridges (4 pcs.)
6	83098	Controller SSE
7	28420	Sealing ring
8	85533	Tension ring
9	28839	Flap switch with plug
10	23093	Outlet flap with magnet
	85477	Nut
	85471	Screw
	93358	Disc
11	23098	Sealing ring
12	28626	Filter cloth
13	23091	Wire cloth
14	28625	Sealing

8. Accessories

- _____
- _____
- _____
- _____